

SECONDARY PULVERIZERS TP-(R)V

Designed for secondary processing to remove rebar and size concrete.
Rotation model, 360 degree hydraulic, increases productivity.
Large model selection is available for most carriers.

AUTHORIZED DEALER

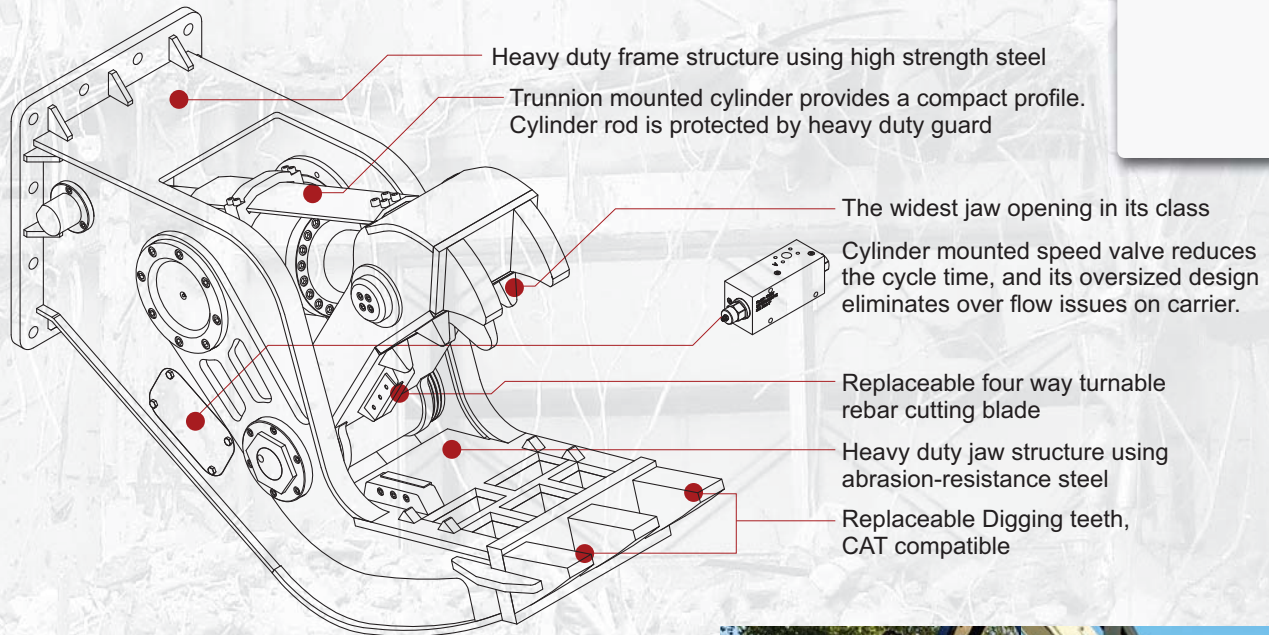

TEETH COMPARISON with W series

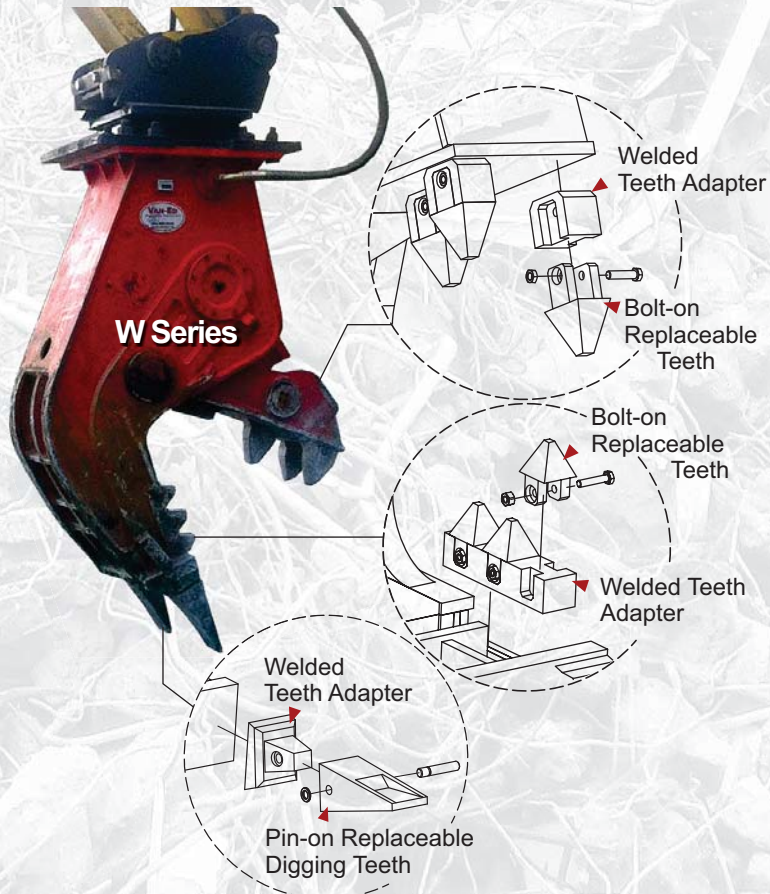

DEMOLITION

SECONDARY PULVERIZERS TP-(R)V

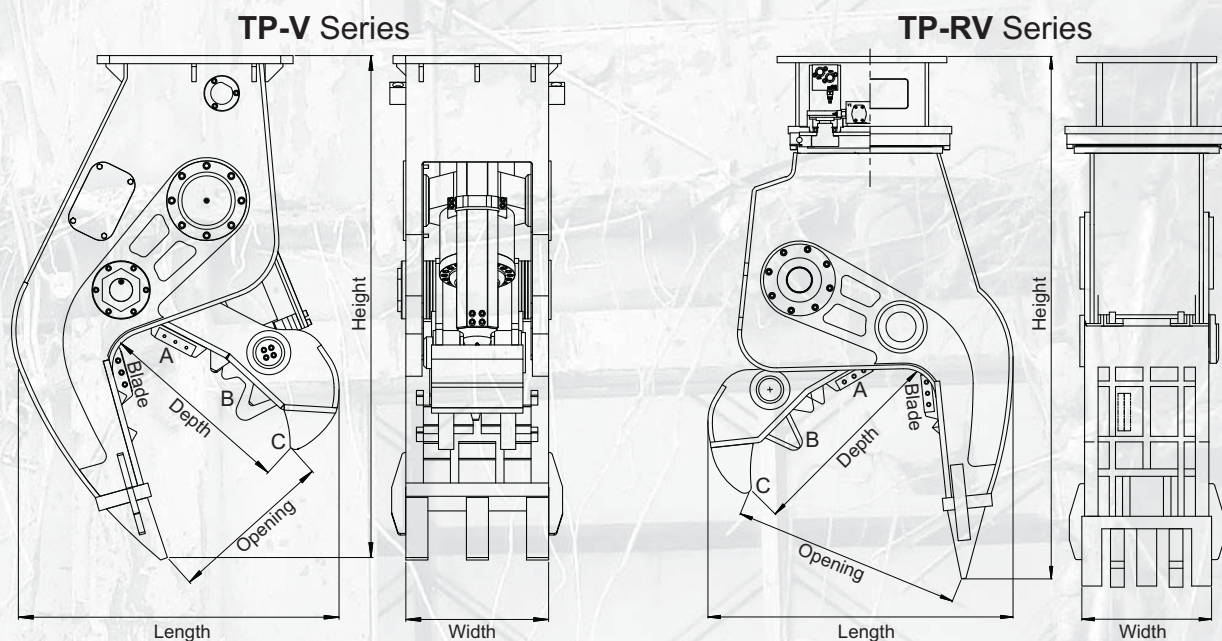

Model	Unit	TP 15V	TP 20V	TP 20RV	TP 30V	TP 35V	Unit	TP 15V	TP 15RV	TP 20V	TP 20RV	TP 30V	TP 35V	
Carrier Weight	M/T	10~20	17~25	20~30	24~35	35~45	M/T	10~20	12~20	17~25	20~30	24~35	35~45	
Operating Weight	kg	950	1,500	1,850	2,450	3,600	lb	2,090	2,530	3,300	4,070	5,390	7,920	
DIM	Height	1,650	1,830	2,090	2,200	2,600	inch	65	73	72	82	87	102	
	Length	1,230	1,250	1,250	1,620	2,200		48	46	49	49	64	87	
	Width	436	520	520	600	830		17	20	20	20	24	33	
Jaw Opening	mm	790	850	920	1,100	1,280	inch	31	31	33	36	43	50	
Jaw Depth		820	825	865	990	1,100		32	32	32	34	39	43	
Blade Length		140	150	150	200	250		5.5	5.5	6.0	6.0	8	9.8	
Cutting Force [A]	M/T (Metric Ton)	163	191	186	257	306	lb (X1,000)	359	359	420	409	566	672	
Crushing Force		[B] Mid	67	91	84	121		132	147	147	200	185	266	291
		[C] Tip	42	60	54	79		98	93	93	132	119	174	216
Rated Pressure	bar	320					psi	4,600						
Rated Oil Flow	lpm	160	280			360	gpm	42	74			95		
Hyd. Rotation	Pressure	bar	-	-	210	-	-	psi	-	3,000	-	3,000	-	-
	Oil Flow	lpm	-	-	40~45	-	-	gpm	-	7~8	-	10~14	-	-
	Speed	RPM	-	-	10~15	-	-	RPM	-	10~15	-	-	-	-
Cycle time	Open	sec	2.1	2.9	2.9	2.4	3.0	sec	2.1	1.9	2.9	2.9	2.4	3.0
	Close		1.9	3.0	3.0	3.1	3.1		1.9	1.8	3.0	3.0	3.1	3.1

Specifications subject to change without notice.

- R model comes come with continuous 360degreee hydraulic rotation.
- Height : Flat Top Mounting
- Cycle Time : Measured at rated flow under no load.